

Instruction Sheet

HIGH-PRESSURE OIL PUMP

T 444E (All Applications)

INTERNATIONAL[®]

1171794R2

Warning: To avoid serious personal injury, possible death, or damage to the engine or vehicle, read all safety instructions in the foreword of corresponding model year service manual.

Identifying Parts

This high-pressure oil pump kit contains the following parts:

- Loctite[®] 680 Sealant
- O-ring seal (3)
- Instruction Sheet (1171794R2)

Description

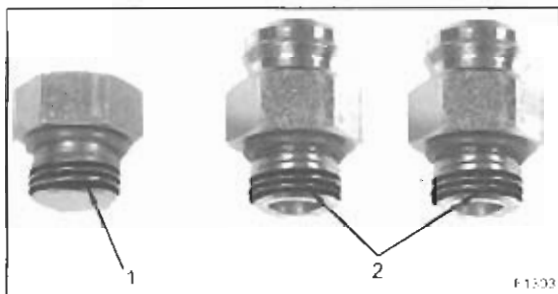

Figure 1 End Plug and Discharge Fittings

1. End plug fitting
2. Discharge fittings (2).

The illustration above shows (1) end plug and (2) discharge fittings with the first three threads with Loctite[®] 680 Sealant.

NOTE: This kit is intended for on vehicle repair only and contains three O-rings and a capsule of Loctite[®] 680 Sealant to be added to only the first three threads.

REMOVAL

Warning: To avoid serious personal injury, possible death, or damage to the engine or vehicle, make sure the transmission is in neutral, parking brake is set, and wheels are blocked before doing diagnostic or service procedures on engine or vehicle.

1. Prepare to collect engine oil from the back of the high-pressure oil pump in the valley area of the engine.
2. Remove end plug from port and discard O-ring.

NOTE: Oil will continue to flow out of port. Use a rag or suitable container to collect oil.

3. Remove both high-pressure oil hoses.
4. Using special tool, No. 6 quick release tool (ZTSE4449), remove both fittings.

NOTE: The high-pressure hose No. 6 quick release tool (ZTSE4449) is available through SPX Corp. by calling: 1-800-520-2584

4. Remove both discharge fittings from the pump and discard O-rings.
5. Remove spring and check assemblies with needle nose pliers.

CLEANING

1. Clean both fittings and end plug ports with a commercially available brake-cleaning product.

NOTE: Be sure both ports in the pump housing are clean and dry.

Instruction Sheet

HIGH-PRESSURE OIL PUMP

T 444E (All Applications)

INTERNATIONAL®

1171794R2

INSTALLATION

CAUTION: Before installing the springs into both ports, make sure that the flat poppet end of the spring goes into the pump housing first. If this is not done it will cause damage to the pump.

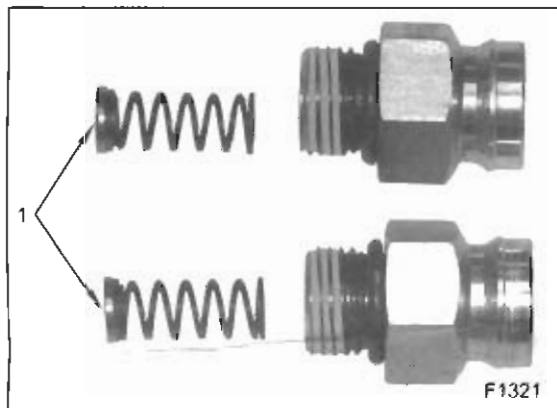

Figure 2 Spring poppet orientation

1. Poppet end

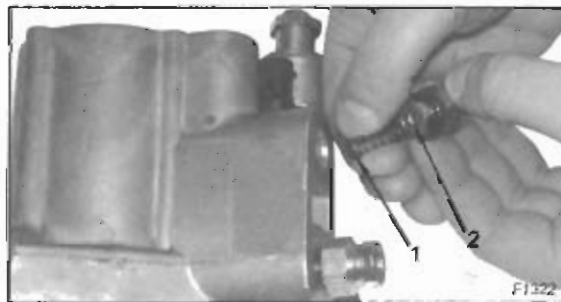

Figure 3 Installing spring and discharge fitting

1. Poppet end
 2. Recess seat in fitting
1. Install spring and check valve assemblies as seen in Figure 3.
 2. Install new O-rings on both discharge fittings and end plug.

3. Apply Loctite® 680 Sealant to only the first three threads on both discharge fittings and end plug.
4. Install both discharge fittings to the pump housing and torque to 34 N·m (25 lbf·ft).
5. Install both high-pressure hoses.

NOTE: Wipe oil from port immediately preceding installation of the plug.

6. Install end plug and torque to 34 N·m (25 lbf·ft).
7. Start engine and check for oil leaks.
8. Check and correct the engine oil level as necessary.

REPLACING THE HIGH PRESSURE PUMP SEALS 7.3L DIESEL MODEL YEARS 1994-2003

KIT - 2C3Z-9G804-AA		
Part Number	Description	Quantity
	O-ring Seals	3
	Loctite® 680 Sealant	1
SK 2C34-9G804-AA	Instruction Sheet	1

SERVICE PROCEDURE:

NOTE: If the oil leak location is undetermined, use the UV leak Detection procedure found in the Workshop Manual.

NOTE: This service kit provides a service procedure for replacing the O-rings without removing the high pressure oil pump.

NOTE: This kit contains three (3) O-rings and a capsule of Loctite® 680 Sealant.

NOTE: If the oil leak originates from the injection pressure regulator (IPR), service the IPR with O-ring kit F6TZ-9C977-AA.

REMOVAL AND INSTALLATION OF DISCHARGE FITTINGS

1. Prepare to collect engine oil from the back of the high-pressure oil pump in the valley area of the engine.
2. Remove end plug from port (refer to Figure 1). Remove and discard O-ring.

NOTE: Oil will continue to flow out of port. Use a rag or suitable container to collect oil.

3. Remove both high-pressure oil hoses at both fittings on the pump using Rotunda Essential Tool #303-625.
4. Remove both discharge fittings from the pump (refer to Figure 1). Remove and discard the O-rings.
5. Remove spring and check assemblies with needle nose pliers.
6. Clean fittings and ports with a commercially available brake cleaning product.

NOTE: Be sure both ports in the pump housing are clean and dry.

7. Install spring and check valve assemblies.
8. Install O-rings on both fittings.
9. Apply Loctite® 680 Sealant to only the first three (3) threads on both discharge fittings.
10. Install both discharge fittings to the pump housing and torque to 34 N•m (25 lbs-ft).
11. Install both high-pressure hoses.
12. Clean end plug port with a commercially available brake cleaning product. Be sure plug is clean and dry.
13. Install new O-ring on end plug.
14. Apply Loctite® 680 to the first three (3) threads.

Ford Motor Company

CPR © 2003 FORD MOTOR COMPANY
DEARBORN, MICHIGAN 48121
6-03

SK 2C34-9G804-AA

SHEET 1 OF 2

REPLACING THE HIGH PRESSURE PUMP
SEALS 7.3L DIESEL MODEL YEARS 1994-2003

NOTE: Wipe oil from port immediately before installation of the plug. Presence of oil will not allow loctite to seal.

15. Install end plug into pump housing and torque to 34 N•m (25 lbs-ft).
16. Start engine and check for oil leaks. Check and correct the engine oil level.

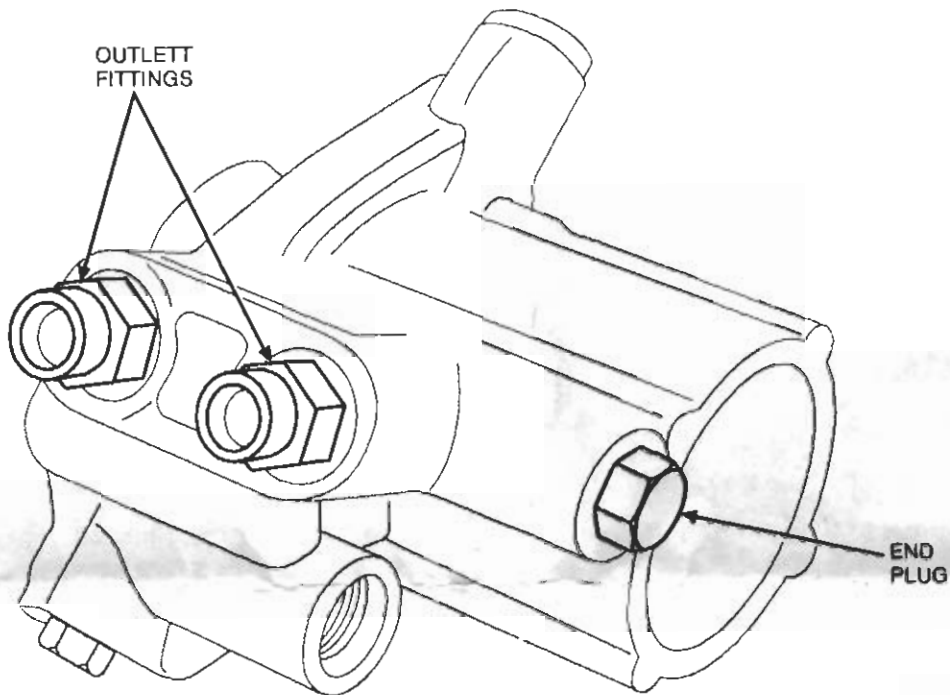

HIGH PRESSURE PUMP FITTINGS

FIGURE 1

Ford Motor Company[™]

© 2003 FORD MOTOR COMPANY
DEARBORN, MICHIGAN 48121
6-03

SK 2C34-9G804-AA

SHEET 2 OF 2

REPLACING THE HIGH PRESSURE PUMP
SEALS 7.3L DIESEL MODEL YEARS 1994-2003